

DESCRIPTION

THE LVD-218 SERIES DLVA'S ARE AVAILABLE IN STANDARD 50dB AND EXTENDED 70/75dB DYNAMIC RANGE OVER THE FULL 2-18 GHz BANDWIDTH, WITH TRUE DC COUPLING. UNITS EMPLOY PLANAR DIODE DETECTORS AND INTEGRATED VIDEO CIRCUITRY FOR HIGH SPEED PERFORMANCE AND OUTSTANDING RELIABILITY. THE DLVA'S ARE OF SUPERIOR CONSTRUCTION USING STATE-OF-THE-ART MIC/MMIC TECHNOLOGY.

FEATURES

- TRULY DC COUPLED
- WIDE BANDWIDTHS
- FAST RISE TIMES
- SHORT RECOVERY TIMES
- SUPERIOR ACCURACY
- EXTENDED DYNAMIC RANGE CAPABILITY
- MINIATURE SIZE
- 1.75 OZ WEIGHT

SPECIFICATIONS

- FREQUENCY RANGE 8.25 - 10.25 GHz
- FREQUENCY FLATNESS @ 20 dBm ±0.5 dB MAXIMUM
- LOGGING RANGE -40 TO -0dBm MINIMUM
- USEFUL RANGE -40 TO +5dBm
- LOG LINEARITY ±1.0dB MAXIMUM @ -40 dBm TO 0 dBm
- LOG SLOPE 100 mV/dB ±5% TOLERANCE
- LOG SLOPE ACCURACY ±4% OF AVERAGE SLOPE
- TEMPERATURE STABILITY ±1.0 dB MAXIMUM (-54° TO +85°C)
- PULSE RESPONSE 50nS TO CW
- RISE TIME 20nS MAXIMUM
- SETTling TIME 45nS MAXIMUM
- RECOVERY TIME -40 TO 0 dBm: 150 nS TYPICAL, 200 nS MAXIMUM
- TSS -40 dBm MINIMUM
- VSWR (RF) 3.0:1
- MAXIMUM RF INPUT +15dBm
- VIDEO OUTPUT LEVEL 0.4 TO 4.4 VOLTS TYPICAL (93 Ω MIN LOAD)
- DC POWER (NO LOAD)
 - +V 12V @ 120MA MAXIMUM (NO VIDEO LOAD)
 - V 12V @ 80MA MAXIMUM
 - OTHER VOLTAGES AVAILABLE
- SIZE 2.2" X 1.5" X 0.4"

OPTIONS

- 9025F OPTIMIZED FOR 8.25 GHz TO 10.25 GHz
- 100MV 100 mV/dB LOG SLOPE

NOTE: THE ABOVE SPECIFICATIONS ARE SUBJECT TO CHANGE OR REVISION

REVISIONS				
ZONE	REV.	DESCRIPTION	DATE	APPROVED
	-	ORIGINAL RELEASE JOB # D704085	05/02/07	

MECHANICAL OUTLINE

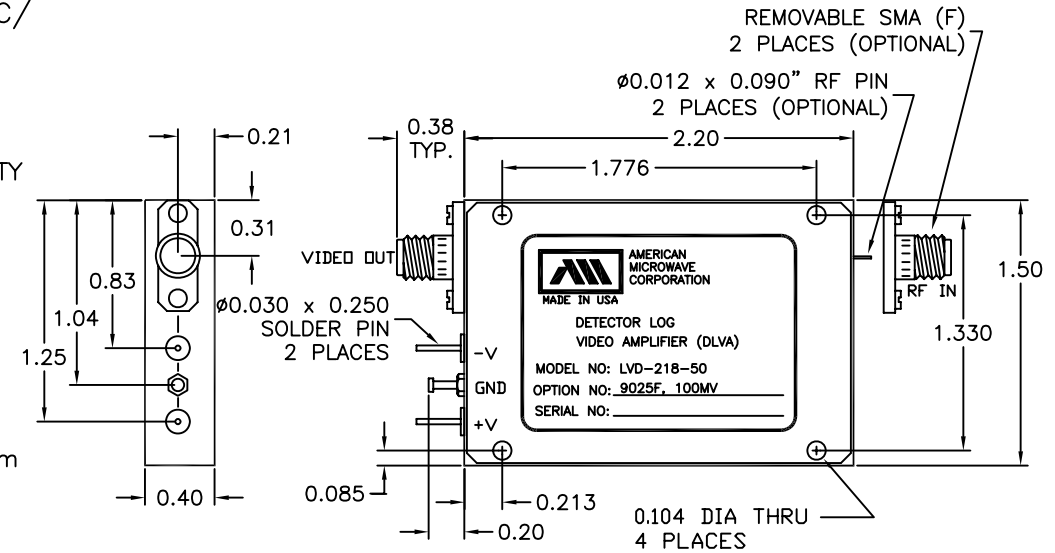

NOTES:

- 1) DIMENSIONS ARE IN INCHES
- 2) TOLERANCES: X.XX ±0.020
X.XXX ±0.010
- 3) WEIGHT: 1.75 OZ

ENVIRONMENTAL RATINGS

- TEMPERATURE -54°C TO +85°C (OPERATING)
-65°C TO +100°C (STORAGE)
- HUMIDITY MIL-STD-202F, METHOD 103B COND. B
- SHOCK MIL-STD-202F, METHOD 213B COND. B
- VIBRATION MIL-STD-202F, METHOD 204D COND. B
- ALTITUDE MIL-STD-202F, METHOD 105C COND. B
- TEMPERATURE CYCLE MIL-STD-202F, METHOD 107D COND. A

		AMERICAN MICROWAVE CORPORATION 7311G GROVE RD., FREDERICK, MD. 21701 TEL: (301) 662-4700 FAX: (301) 662-4938	
APPROVALS	DATE	PRODUCT FEATURE	
DRAWN <i>WJL</i>	05/02/07	LVD-218-50 OPTION 9025F, 100MV	
MODIFIED <i>BB</i>	05/02/07	2 TO 18 GHz, 40/45dB, TRULY DC-COUPLED DETECTOR LOG VIDEO AMPLIFIER	
CHECKED		SIZE A	SHEET 1 OF 2
		DWG. # 100-2811-009	REV -

REVISIONS				
ZONE	REV.	DESCRIPTION	DATE	APPROVED
	-	ORIGINAL RELEASE JOB # D704085	05/02/07	

FUNCTIONAL BLOCK DIAGRAM

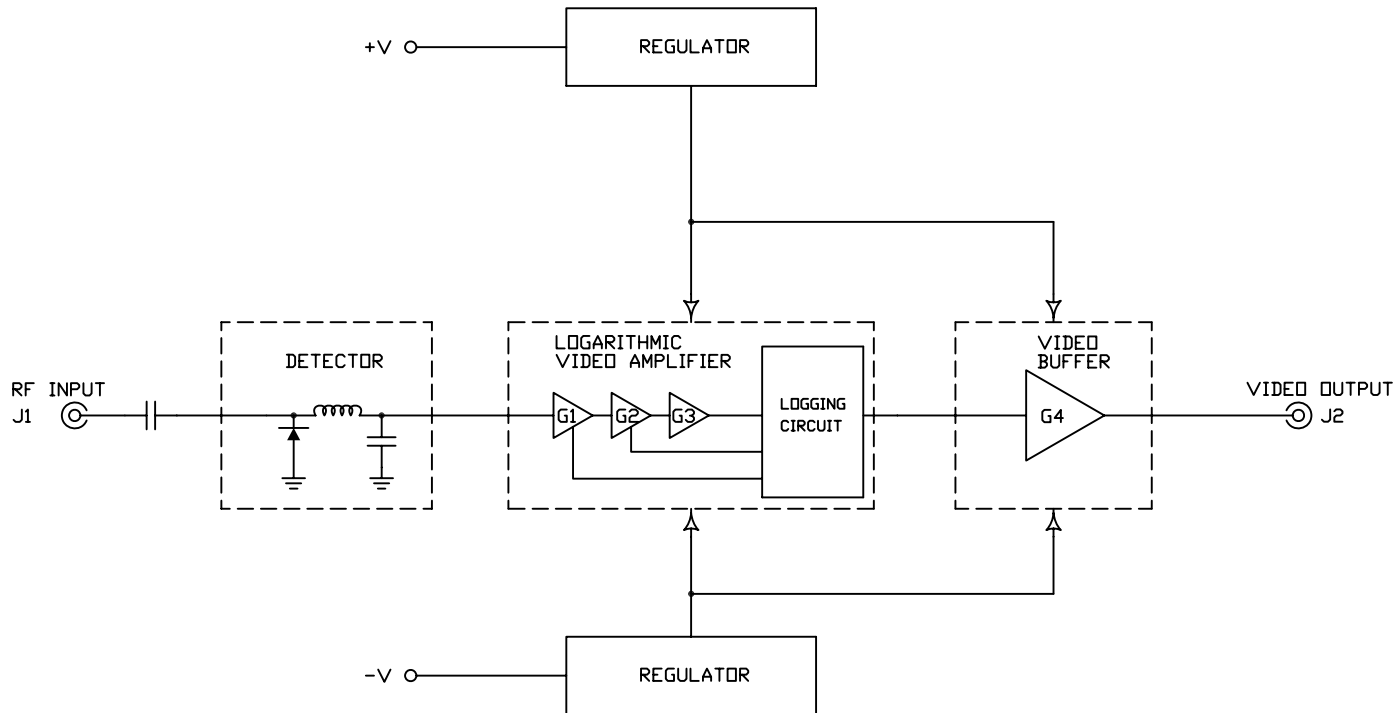

		AMERICAN MICROWAVE CORPORATION 7311G GROVE RD., FREDERICK, MD. 21701 TEL: (301) 662-4700 FAX: (301) 662-4938		
		FUNCTIONAL SCHEMATIC LVD-218-50 OPTION 9025F, 100MV 2 TO 18 GHz, 40/45dB, TRULY DC-COUPLED DETECTOR LOG VIDEO AMPLIFIER		
APPROVALS	DATE	SIZE	SHEET	DWG. #
DRAWN <i>WFLP</i>	05/02/07	A	1 OF 2	100-2811-009
MODIFIED <i>BB</i>	05/02/07			
CHECKED				REV -